

Dynamic Contour Tonometry in Comparison to Intracameral IOP Measurements

Andreas G. Boehm,¹ Anja Weber,¹ Lutz E. Pillunat,¹ Rainer Koch,² and Eberhard Spoerl¹

PURPOSE. The purpose of the study was to examine the effect of central corneal thickness (CCT), corneal curvature, astigmatism, axial length (AL), and age on measurements with the Pascal Dynamic Contour Tonometer (DCT).

METHODS. In a prospective clinical trial 75 eyes of 75 patients undergoing phacoemulsification were examined. Before phacoemulsification, the anterior chamber was cannulated at the temporal corneal limbus. In a closed system the IOP was directly set to 15, 20, or 35 mm Hg with a manometric water column. IOP measurements taken by DCT were compared to intracameral measurements with a precision reference pressure sensor.

RESULTS. Measurements from 60 patients were suitable for statistical analysis. At IOP of 15 mm Hg, the mean difference between IOP measured by DCT and intracameral IOP was -0.02 ± 1.32 mm Hg; at 20 mm Hg it was -0.2 ± 1.44 mm Hg and at 35 mm Hg, -0.84 ± 1.90 mm Hg. The concordance coefficient according to Lin was 0.9763, showing good agreement between DCT- and intracamerally measured IOP. There was a statistically significant correlation between the difference in IOP measured by DCT minus intracameral IOP and CCT ($P = 0.0291$, $R^2 = 0.00012$). All other parameters had no statistically significant effect on the difference between DCT and intracameral IOP (corneal curvature, $P = 0.6094$, $R^2 = 0.00367$; age, $P = 0.9198$, $R^2 = 0.000003$; astigmatism, $P = 0.1564$, $R^2 = 0.08497$; and axial length, $P = 0.9484$, $R^2 = 0.00008$).

CONCLUSIONS. Measurements with the DCT showed good concordance with intracameral IOP. CCT exerted a statistically significant but clinically irrelevant effect on measurements with the DCT. (*Invest Ophthalmol Vis Sci.* 2008;49:2472-2477) DOI:10.1167/iovs.07-1366

Goldmann applanation tonometry (GAT) has been the gold standard in tonometry for more than 50 years. However, there are possible sources of error that may lead to an under- or overestimation of the real IOP in individual patients.

Factors that may affect the GAT readings, are either caused by the measurement procedure itself (e.g., thin or thick rings) or by properties of the eye (e.g., corneal thickness, corneal curvature, astigmatism, and axial length).¹ Particularly, the effect of corneal thickness on GAT has been discussed extensively.²⁻⁵ A correction factor has been suggested of from 0.19 to 1 mm Hg per 10- μ m deviation from the average corneal

thickness. However, in most of the studies, correlations in a large cohort of subjects were calculated without knowing the real IOP. To overcome this problem, intracameral measurements seem to be the most appropriate approach to assessing the effect of properties of the eye on IOP measurements by comparing measured IOP with the real (intracameral) IOP, as suggested by Ehlers.^{6,7} In a recent study, our group showed a correction factor for GAT of 1 mm Hg per 25- μ m difference from a central corneal thickness (CCT) of 550 μ m in intracameral measurements, showing that corneal thickness has a major impact on GAT measurements.⁵ However, in a given patient, it is still unclear whether a correction of the measured IOP according to correction tables is the appropriate way to determine the real IOP.

A dependency of IOP readings on CCT seems to be unfavorable, as a thin corneal thickness was considered to be a major risk factor for conversion to glaucoma in the OHTS study^{8,9} and for progression in patients with glaucoma.¹⁰ It is still unclear whether this finding is caused by the corneal-thickness dependency of GAT or is an independent risk factor.

Therefore, it seems desirable to have a tonometer that is, ideally, independent of corneal thickness and other ocular parameters. Recently, the Pascal Dynamic Contour Tonometer (DCT) was introduced.¹¹ The idea behind this instrument is that the tonometer tip has a special shape allowing a direct IOP measurement by minimizing corneal stress. The purpose of the present study was to examine in an intracameral in vivo study whether measurements with the DCT are affected by CCT, corneal curvature, and axial length and to answer the question of whether IOP measurements by DCT represent the real IOP.

METHODS

In this prospective clinical trial, 75 eyes of 75 consecutive patients scheduled for cataract surgery were included. The indication for cataract surgery was independent from participation in the study.

Exclusion criteria were a history of previous ocular trauma or surgery, any corneal disease or irregularity, or proliferative diabetic retinopathy.

All patients signed an informed consent before entering the study. The study was performed in accordance with the Declaration of Helsinki and was approved by the institutional ethics committee of the Medical Department of the University of Dresden.

Before entering the study, all patients underwent a complete ophthalmic examination. In addition, keratometry was performed with a keratometer (Zeiss Bombe; Carl Zeiss Meditec, Inc., Dublin, CA), axial length was measured by A-scan ultrasonography (Sonomed 2500; Technomed, Maastricht, The Netherlands), and CCT was measured with an ultrasonic pachymeter (IOPac; Heidelberg Engineering, Heidelberg, Germany).

After surgery, the patients received peribulbar anesthesia (2.5 mL bupivacaine 0.75%, 2.5 mL mepivacaine 2%, and hyalase 150 IU in 1 mL), and 0.5% proxymetacaine eye drops were used to anesthetize the cornea. After the peribulbar injection a Vörösmarthy oculopressor was used with a pressure of 30 mm Hg for 10 minutes. This device applies pressure via an inflatable balloon to the outside of the eye through the closed eyelid to soften the eye and improve the effectiveness of the local anesthetic.¹²

From the ¹Department of Ophthalmology and the ²Institute of Medical Statistics and Biometry, University of Dresden, Dresden, Germany.

Submitted for publication October 23, 2007; revised December 14, 2007, and January 31, 2008; accepted April 15, 2008.

Disclosure: A.G. Boehm, None; A. Weber, None; L.E. Pillunat, None; R. Koch, None; E. Spoerl, None

The publication costs of this article were defrayed in part by page charge payment. This article must therefore be marked "advertisement" in accordance with 18 U.S.C. §1734 solely to indicate this fact.

Corresponding author: Andreas G. Boehm, Department of Ophthalmology, University of Dresden, Fetscherstrasse 74, 01307-Dresden, Germany; boehm@uniklinikum-dresden.de.

IOP measurements were performed before actual surgery. All measurements and the subsequent cataract surgery were performed by one examiner (AGB). Before the IOP measurements began, the experimental tubing system was adjusted to the height of the eye according to a laser water scale (Fig. 1).

After the eyelid retractor was placed, the anterior chamber was cannulated at the temporal corneal limbus. The cannula (inner diameter, 0.4 mm; outer diameter, 0.7 mm) was connected via a multiple stopcock system to an adjustable water column filled with physiologic saline (PSS; Balanced Salt Solution; Alcon Ltd., Fort Worth, TX) as well as to a pressure sensor used as reference. This reference sensor was a DCT tip directly connected with the water column allowing intracameral IOP measurements. When connected directly to the water column, the DCT tip acts like a conventional pressure sensor and does not use the principle of DCT. IOP was directly calibrated by changing the height of the water column in relation to the eye (open system). The three different IOP levels (15, 20, and 35 mm Hg) were adjusted in a random sequence (three-period crossover). After each IOP level was reached, the system was closed, and three consecutive measurements were taken (closed system). IOP was measured simultaneously with the reference sensor intracamerally and via DCT from the outside. The measurement principle of the DCT has been described in detail elsewhere.¹¹ Because the measurements had to be performed with the subject in a supine position, we used a hand-held DCT. The hand-held DCT, which is basically a DCT tip mounted on the body of a Perkins tonometer, allows DCT measurements independent of body position (Fig. 2). This instrument was developed by Ziemer Ophthalmic Systems AG (Port, Switzerland). In the following description, the term DCT measurements refers to the measurements with the hand-held DCT, and reference refers to the DCT tip integrated into the tube system to obtain intracameral measurements.

The IOP was measured continuously by the DCT and the reference. The instruments provide the diastolic IOP. Therefore, all IOPs in this article represent the diastolic IOP. The diastolic IOP was averaged over four to six heart cycles to reduce intraindividual variation. The measurements of the DCT and the reference were transferred to a computer. The IOP curves were analyzed with a software feature called range interpreter (Swiss Microtechnology AG, Port, Switzerland; Fig. 3). For the DCT and the reference, the same time interval was used.

Much caution was used to perform the hand-held DCT tonometer measurements correctly. The tip of the tonometer was applied centrally without tilting. The corneal surface was moistened with artificial tears (Systane AT; Alcon Ltd., Herts, UK) during the measurements.

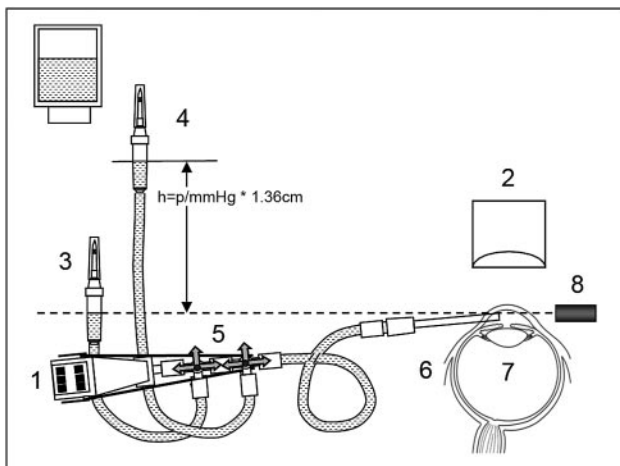

FIGURE 1. Experimental tubing system. The stopcock positions shown created a closed system for intracameral IOP measurement. (1) DCT pressure-sensing tip; (2) reference sensor measuring IOP manometrically; (3) compensation container; (4) pressure container, variable in height; (5) stopcock systems; (6) catheter tube; (7) human eye; (8) laser.

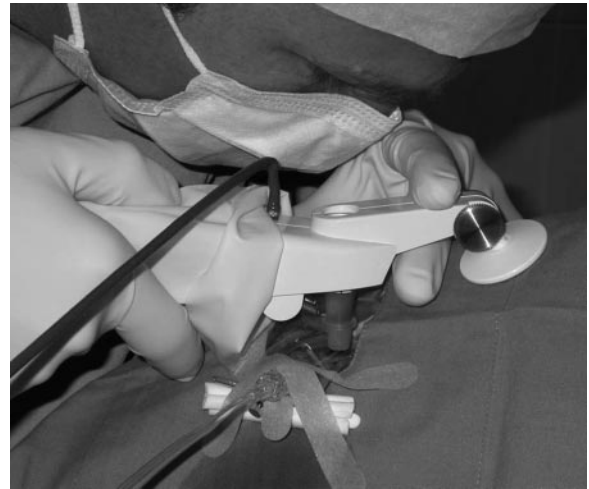

FIGURE 2. Measurement of the IOP with the hand-held DCT in a cannulated eye.

Excessive liquid was removed by means of a sponge, to avoid the floating of the measurement tip. If no pulsation of the IOP was audible after the measurement tip was applied to the cornea, the measurements were aborted and not included in the statistical analysis.

The instrument provides an internal quality assessment of the measurement in five levels: from 1 representing the best quality to 5 representing the worst. The manufacturer recommends that only measurements equal to or better than quality level 3 be used. Therefore, only measurements of a quality of 3 or better were used for the statistical evaluation, and measurements of quality levels 4 and 5 were excluded.

After completion of the study, each measurement curve was reevaluated by a masked observer. If the IOP was determined in a stable part of the measurement curve and if the measurements were not disturbed by artifacts, the measurements were used for the analysis. All other measurements were excluded.

Before starting with the 60 patients who were included in the study, we performed 10 measurements to avoid having learning effects bias the study. During these training measurements, it was apparent that if the positioning of the cannula caused high tension on the cornea, it led to large differences between measured IOP and reference IOP. For example, in one case the DCT initially showed an IOP of 9 mm Hg lower than reference. Looking at the site of cannulation, it was apparent that the cannula was under tension, as it was bent upward. After reducing the tension by changing the position of the cannula the difference between DCT and reference was reduced to 0.5 mm Hg. Therefore, we used great caution to insert the cannula into the anterior chamber with the least resulting tension for the measurements. As a consequence, if the cannula showed high tension on the cornea the measurements were aborted and not used for analysis.

For statistics, a linear model of analysis of covariance (mixed procedure) was used. In the model, all 60 patients were viewed as randomized effects. As an assumption, identical correlations between the intraindividual repeated measurements were used (compound symmetry).

For comparison of the DCT and reference measurements, the analysis evaluates the agreement of two methods with different measurement error variance. The model includes IOP levels (15, 20, and 35 mm Hg); periods 1, 2, and 3; and methods (DCT, reference) as experimental factors and the dual and triple interactions of the experimental factors. To assess the grade of concordance of both quantitative measurements, the concordance correlation coefficient according to Lin was calculated. In addition, Bland-Altman plots were used. The reproducibility was assessed by calculating intraclass coefficients.

For the evaluation of the effect of different factors on the IOP difference between DCT and reference, the model additionally used

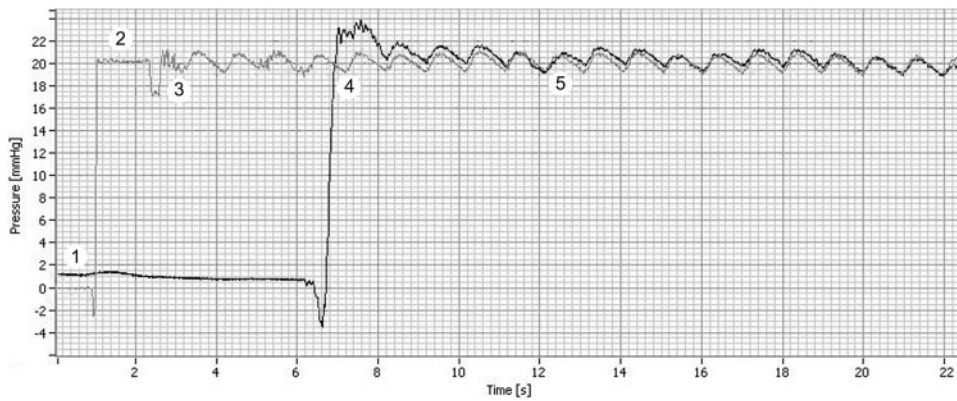

FIGURE 3. Graph of a measurement with the reference (gray) and the DCT (black) at the 20-mm Hg level. (1) Simultaneous start of DCT and reference with determination of the 0 level that will serve as the reference. (2) The reference shows IOP 20 mm Hg with the water column open and not connected to the eye. (3) The column is closed and connected to the eye with starting pulsation. (4) The DCT is applied on the corneal surface and DCT measurement starts. (5) Simultaneous IOP curves of reference and DCT.

CCT, corneal curvature, age, astigmatism, and axial length as quantitative covariables.

The analysis was performed with commercial software (SAS, ver. 9, using PROC MIXED; SAS Institute Inc., Cary, NC).

RESULTS

Of the initial 75 patients, 15 had to be excluded from the data analysis: 8 patients showed distortion of the cornea by the cannula tip, and 7 showed no pulsation of IOP after the DCT tip was applied to the cornea. Therefore, the measurements of the remaining 60 eyes of 60 patients were used for the statistical analysis. Of the 60 patients, 43 were women and 17 were men with a mean age of 73.4 ± 9.4 years (range, 49–96 years). Four patients had primary open angle glaucoma, one had ocular hypertension, and one had suspected glaucoma determined by disc appearance. Thirteen subjects had diabetes mellitus and 37 had systemic hypertension.

Mean CCT was $562 \pm 36 \mu\text{m}$ (mean \pm SD) ranging from 464 to 626 μm . Corneal curvature was $43.7 \pm 1.7 \text{ D}$ (40.6–50.9 D), astigmatism $1.0 \pm 0.9 \text{ D}$ (0–5.25 D), and axial length $23.05 \pm 1.33 \text{ mm}$ (21.27–27.81 mm), respectively. The descriptive statistics of the IOP measurements are summarized in Table 1.

Over all measurements, there was no statistically significant difference between DCT measurements and reference IOP ($P = 0.1232$). When we compared DCT and reference IOP for each level separately, there was no statistically significant difference at the level of 15 ($P = 1.00$) or 20 ($P = 0.9223$) mm Hg. However, at the level of 35 mm Hg, DCT showed significantly lower IOPs (0.89 mm Hg) compared with the reference ($P = 0.0125$; Fig. 4).

Examination of the effect of period on the measurements with the DCT showed a statistically significant difference only between the second and third periods at the level of 35 mm Hg

($P = 0.0348$). All other comparisons were not significantly different ($P > 0.05$). The correlation between the DCT measurements and the intracameral measurements is shown in Figure 5.

Over all measurements, the concordance coefficient according to Lin was 0.9763, showing good agreement between DCT and reference. The Bland-Altman plot showing the mean of the DCT and the reference IOP measurement plotted against the difference of both measurements is shown in Figure 6. The data describing the reproducibility of the measurements are displayed in Table 2.

When the patients were divided into different groups, there was no statistically significant difference in IOP measurements (DCT, reference) and IOP differences (DCT-reference) in males versus females, patients with systemic hypertension versus patients without systemic hypertension, and patients with glaucoma versus those without ($P > 0.05$). However, patients with diabetes tended to have higher IOPs than did the subjects without diabetes (0.16 mm Hg, $P = 0.037$). There was no statistically significant difference in IOP differences (DCT minus reference) between patients with diabetes and patients without diabetes ($P > 0.05$).

The difference between DCT and reference IOP increased with increasing IOP level ($P < 0.001$). Comparison of the single IOP levels showed that the differences were significantly higher at 20 than at 15 mm Hg ($P = 0.0465$), at 35 mm Hg than

TABLE 1. Descriptive Statistics

BH (mm Hg)	Instrument	n	IOP (mm Hg)			
			Mean	SD	Min	Max
15	DCT	168	15.41	1.68	11.14	20.13
	Reference	171	15.41	1.05	13.54	19.28
	DCT-Reference	168	-0.02	1.32	-3.46	3.33
20	DCT	167	19.68	1.78	15.95	24.47
	Reference	168	19.90	1.11	17.41	22.66
	DCT-Reference	167	-0.20	1.44	-4.18	3.01
35	DCT	167	32.21	2.48	26.16	39.88
	Reference	170	33.10	1.78	26.40	37.11
	DCT-Reference	167	-0.84	1.90	-5.88	3.12

BH, bottle height.

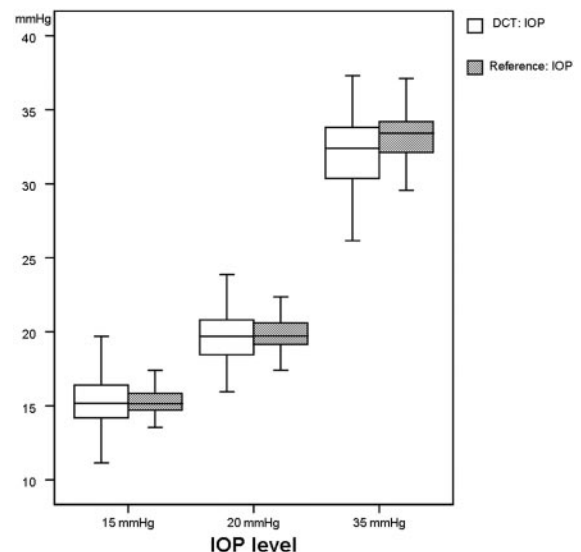

FIGURE 4. IOP distribution for DCT and reference at the different IOP levels.

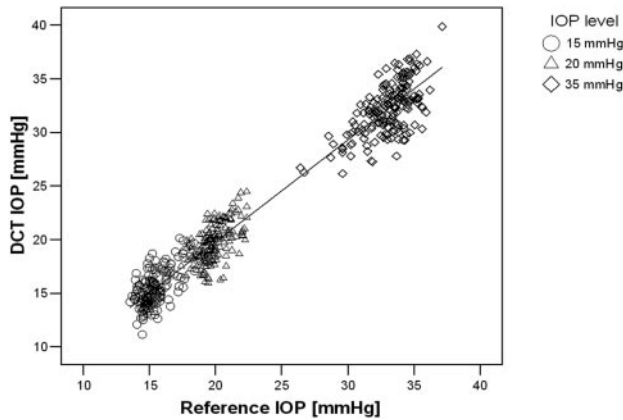

FIGURE 5. Scatterplot showing the correlation between intracameral (reference) and DCT IOP measurements ($R = 0.977$; $P < 0.001$).

at 15 ($P < 0.001$), and at 35 than at 20 mm Hg ($P < 0.001$), respectively.

In the multivariate regression analysis, CCT had a statistically significant effect on the difference between DCT and reference IOP ($P = 0.0291$). An increase in CCT of 92 μm led to an IOP increase of 1 mm Hg. All other parameters had no statistically significant effect on the difference between DCT and reference IOP (corneal curvature, $P = 0.6094$; age, $P = 0.9198$; astigmatism, $P = 0.1564$; and axial length, $P = 0.9484$). However, in the multivariate model the R^2 -values were very low for all parameters including CCT with $R^2 = 0.00012$. The other R^2 -values were 0.00367 for corneal curvature, 0.000003 for age, 0.08497 for astigmatism, and 0.00008 for axial length. The univariate linear regression comparing CCT with the difference between DCT and reference IOP is shown in Figure 7.

DISCUSSION

To our knowledge, the present study is the first to compare intracameral IOP measurements with readings obtained by DCT. The DCT measurements showed a good concordance with intracamerally measured IOP. The overall good agreement is demonstrated by the concordance correlation coefficient according to Lin of 0.9673. However, the agreement between

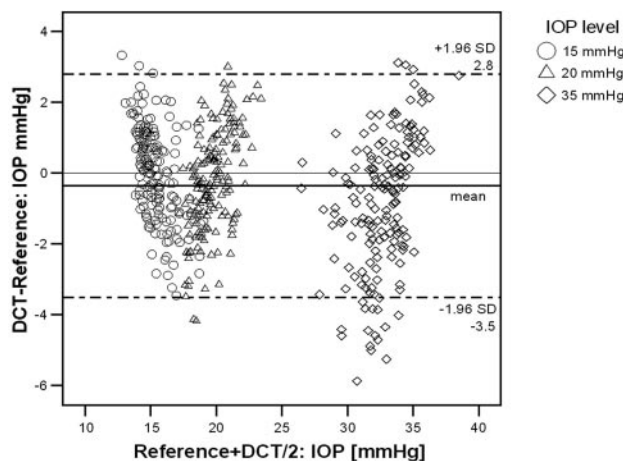

FIGURE 6. Bland-Altman plot showing the mean of the DCT and the reference IOP measurements plotted against the difference between both measurements.

TABLE 2. Residual Variances and Intraclass Coefficients (ICCs) by IOP Level and Method

BH (mm Hg)	Instrument	n	Residual Variance	Residual SD (mm Hg)	ICC
15	DCT	168	0.50	0.71	0.82
	Reference	171	0.23	0.48	0.79
20	DCT	167	0.86	0.93	0.71
	Reference	168	0.39	0.63	0.68
35	DCT	167	1.90	0.71	0.63
	Reference	170	1.18	0.48	0.59

BH, bottle height.

DCT and intracameral IOP was better at the lower IOP levels (15 and 20 mm Hg) than at the highest level of 35 mm Hg.

The reason for the reduced concordance at the highest IOP level is not clear. One possible explanation is that the experimental setup was more susceptible to errors at higher IOP levels than at lower levels. This hypothesis is supported by the fact that the difference between DCT and real IOP increased with increasing IOP level and the scattering of measurements increased toward higher IOPs.

A similar trend was seen with regard to the reproducibility. Although the overall reproducibility was good, the reproducibility decreased toward higher IOP levels. In the literature a good reproducibility of the DCT measurements is supported by many authors. The reproducibility of the DCT readings seems to be even better than GAT readings.¹³⁻²⁰

The idea in the present study was to compare IOP measured intracamerally with that measured by DCT. Differences between the two can mainly be caused by four sources of error: First, properties of the eyes affecting the measurements; second, the experimental setup; third, the measurement procedure itself; and fourth, the possibility that the instrument does not measure IOP correctly. As the same type of pressure sensor was used to measure both the intracameral and the transcorneal IOP, the fourth possibility seems to be irrelevant in our setup.

Effect of Eye Properties on the Measurements

Corneal curvature, age, astigmatism, and axial length showed no statistically significant effect on the difference between

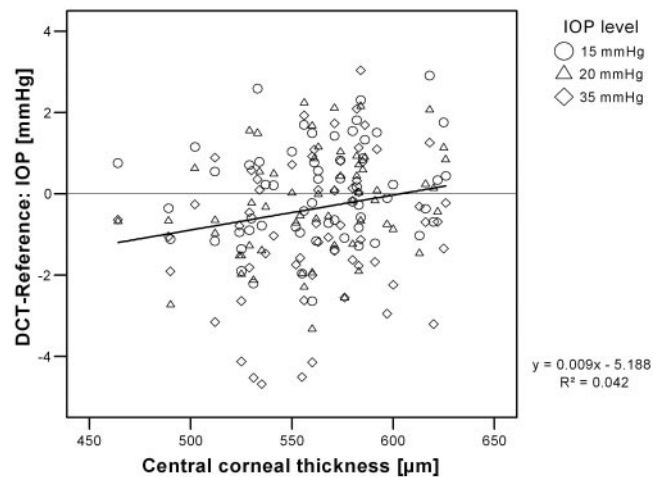

FIGURE 7. Univariate regression analysis between CCT and the difference between DCT and reference measurements. Note that the R^2 -value is still low, but is higher than in the multivariate regression analysis.

intracameral IOP and DCT measurement. However, CCT had a significant effect on the difference of intracameral IOP and DCT reading. A CCT increase of 92 μm led to an increase in the DCT reading of 1 mm Hg. However, compared with data from a previous study comparing intracameral IOP with GAT, in which a 25- μm change in CCT leads to an error of 1 mm Hg,⁵ which is almost fourfold, the effect of CCT on DCT seems to be very small. In addition, the correlation of CCT and DCT was very weak with $R^2 = 0.00012$ and $P = 0.0291$ and therefore seems to be clinically irrelevant. This finding is in agreement with studies comparing DCT and GAT measurements showing that DCT readings seem to be less (or not) affected by CCT than are GAT measurements.^{16,18–23}

Critical Evaluation of the Experimental Setup

The tonometer used in the study is not identical with the commercially available Pascal DCT. As the measurements were performed with the subjects supine, a hand-held DCT was used, which is a DCT tip mounted on the body of a Perkins tonometer, allowing measurements independent of body position. As exactly the same measurement tip is used in the hand-held device and the commercially available Pascal DCT, it seems unlikely that IOP readings differ significantly between both instruments. This is supported by a study performed by Roberts et al. (*IOVS* 2007;48:ARVO E-Abstract 1254), comparing both devices and showing good agreement between both instruments, suggesting that **the results of the present study are also applicable to the commercially available Pascal DCT**.

In the present study, both the hand-held DCT and intracameral IOP measurements were obtained with identical DCT tips. Therefore, the same pressure gauge in the DCT tip was used for both measurements. If the pressure gauge delivered incorrect pressure measurements, it could lead to a systematic error. However, the calibrations of the pressure sensors of both instruments were verified against a water column before the experiments. In addition, a verification of calibration was performed automatically during each measurement, when the intracameral pressure sensor was connected to the water column (Fig. 3, phase 2). Therefore, this source of error can be excluded.

As the measurements were performed before cataract surgery, the eyes were anesthetized by peribulbar injection and softened by application of pressure from outside with an ocupression device. Both procedures could affect the aqueous dynamics and therefore be a potential source of error. However, as the IOP was set to certain IOP levels manometrically, and reference as well as DCT measurements were taken simultaneously, it seems unlikely that this had a significant effect on the results.

As pointed out in the Material and Methods section, the initial measurements before the study began showed possible measurement errors, if tension of the cannula was present. Therefore, caution was exercised to minimize the tension of the cannula on the cornea. However, it cannot be fully excluded that at least to some extent such tension influenced the results. However, despite this possible problem, the concordance between measurements was good. If this effect was present during the measurements, one would hypothesize that the agreement between intracameral and measured IOP may have been even better than reported in this article. Therefore, we have initiated a study in which the astigmatism induced by the cannulation is measured to evaluate how this might affect measurements.

It is also possible that the tension of the cornea is more pronounced at higher IOPs, as according to Laplace's law the tension in the cornea increases with increasing IOP. As we described in our empiric data, increased tension resulted in a

falsely low measurement of IOP. This false reading may be at least partly an explanation of why the measured IOPs were significantly lower compared with the intracameral IOP at higher IOPs.

In contrast to other studies, we chose to compare the measured values with the values obtained with the reference IOP instead of comparing them with the adjusted IOP level (15, 20, and 35 mm Hg). The reason is that the IOP is not steady, but fluctuates due to the heart action. This fluctuation is measured by the instrument as ocular pulse amplitude, indicating the difference between the diastolic and systolic IOP. Measurements were performed in a closed system. The DCT considers the diastolic IOP only. However, if the system were closed during systole, the diastolic IOP measured by DCT would be lower by approximately the amount of the pulse amplitude. Another advantage of using the intracameral measurement is the possibility of comparing it continuously with the measured IOP (Fig. 3). Therefore, using the measured IOP reduces possible sources of error.

Of interest, at the IOP level of 35 mm Hg, the difference between adjusted IOP level and IOP measurements was higher than at the other two IOP levels. The reason for this finding is that although the stopcocks were closed during the measurements, the system was not totally closed. Trabecular meshwork and uveoscleral outflow remained open and allowed outflow with a consecutive IOP decrease. Therefore, it seems to be even more important at higher IOP levels not to use the adjusted but the measured intracameral IOP as a reference. Although the model used is not an ideal system, it comes as close as possible to a closed system, and at lower IOPs, the effect seems to be negligible.

Comparison of DCT with GAT

GAT has been the gold standard of tonometry for more than 50 years. Over the years, it has been a helpful tool in the diagnosis and treatment of glaucoma. However, there are still some problems involved in GAT measurements. Because of its measurement principle, it does not measure IOP, but the force that is needed to appanate a circle with a diameter of 3.06 mm. Under certain conditions, the force is directly proportional to the IOP and is valid for most patients; however, for many others, it is not.

That this is really a relevant issue is reflected in reports in which IOP measured with GAT was high due to measurement error, whereas the intracameral IOP was normal.^{24,25} In addition, patients with normal-pressure glaucoma tend to have a thinner CCT, and those with OHT tend to have a thicker CCT compared with normal subjects, suggesting that at least some of these patients are misclassified because of a measurement error caused by the CCT deviation.²⁶ Because of the dependency of GAT measurements on CCT, the use of nomograms to correct measurements has been suggested. However, adjusting IOP measurements according to a nomogram seems to be problematic, as it is possible that the corrected IOP will be even more different from the true IOP than in the initial measurement.²⁷

Therefore, it would be much more desirable to have a tonometer that measures independent of or is at least less dependent on the properties of the eye (e.g., CCT). **As shown in our study, the DCT provides measurements with a high accuracy and reproducibility.** The concordance between true IOP and measured IOP seems to be higher compared with the GAT measurements, as CCT and other parameters had no clinically relevant effect, and therefore no correction of the IOP measurements was necessary. **According to our data, the DCT measurements came close to the true IOP** and seem to be at least a good alternative to GAT, especially if CCT needs to be considered.

In summary, measurements with the Pascal DCT show good accuracy and reproducibility. The measurements are not dependent on astigmatism, corneal curvature, and axial length. There was only a small statistically significant effect of CCT on DCT readings, which seems to be clinically irrelevant. Therefore, the DCT measurements come close to true IOP.

References

- Whitacre MM, Stein R. Sources of error with use of Goldmann-type tonometers. *Surv Ophthalmol*. 1993;38(1):1-30.
- Shah S, Chatterjee A, Mathai M, et al. Relationship between corneal thickness and measured intraocular pressure in a general ophthalmology clinic. *Ophthalmology*. 1999;106(11):2154-2160.
- Stodtmeister R. Applanation tonometry and correction according to corneal thickness. *Acta Ophthalmol Scand*. 1998;76(3):319-324.
- Whitacre MM, Stein RA, Hassanein K. The effect of corneal thickness on applanation tonometry. *Am J Ophthalmol*. 1993;115(5):592-596.
- Kohlhaas M, Boehm AG, Spoerl E, et al. Effect of central corneal thickness, corneal curvature, and axial length on applanation tonometry. *Arch Ophthalmol*. 2006;124(4):471-476.
- Ehlers N, Bramsen T, Sperling S. Applanation tonometry and central corneal thickness. *Acta Ophthalmol (Copenh)*. 1975;53(1):34-43.
- Ehlers N, Hansen FK. Central corneal thickness in low-tension glaucoma. *Acta Ophthalmol (Copenh)*. 1974;52(5):740-746.
- Brandt JD, Beiser JA, Kass MA, Gordon MO. Central corneal thickness in the Ocular Hypertension Treatment Study (OHTS). *Ophthalmology*. 2001;108(10):1779-1788.
- Gordon MO, Beiser JA, Brandt JD, et al. The Ocular Hypertension Treatment Study: baseline factors that predict the onset of primary open-angle glaucoma. *Arch Ophthalmol*. 2002;120(6):714-720; discussion 829-830.
- Medeiros FA, Sample PA, Zangwill LM, et al. Corneal thickness as a risk factor for visual field loss in patients with preperimetric glaucomatous optic neuropathy. *Am J Ophthalmol*. 2003;136(5):805-813.
- Kanngiesser HE, Kniestedt C, Robert YC. Dynamic contour tonometry: presentation of a new tonometer. *J Glaucoma*. 2005;14(5):344-350.
- Vörösmarthy D. Oculopression: types and methods of application, possibilities of utilisation. *Bibl Ophthalmol*. 1966;69:42-99.
- Herdener S, Pache M, Lautebach S, Funk J. Dynamic contour tonometry (DCT) versus Goldmann applanation tonometry (GAT): a comparison of agreement and reproducibility. *Graefes Arch Clin Exp Ophthalmol*. 2007;245:1027-1030.
- Francis BA, Hsieh A, Lai MY, et al. Effects of corneal thickness, corneal curvature, and intraocular pressure level on Goldmann applanation tonometry and dynamic contour tonometry. *Ophthalmology*. 2007;114(1):20-26.
- Viestenz A, Langenbacher A, Viestenz A. Reproducibility of dynamic contour tonometry: comparison with TonoPenXL and Goldmann applanation tonometry—a clinical study on 323 normal eyes (in German). *Klin Monatsbl Augenheilkd* 2006;223(10):813-819.
- Martinez-de-la-Casa JM, Garcia-Feijoo J, Vico E, et al. Effect of corneal thickness on dynamic contour, rebound, and Goldmann tonometry. *Ophthalmology*. 2006;113(12):2156-2162.
- Hoffmann EM, Pfeiffer N, Barleon L, Grus FH. Goldmann applanation tonometry and dynamic contour tonometry: comparison of intraocular pressure measurements in the course of product certification according to EN ISO 8612:2001 (in German). *Ophthalmologie*. 2006;103(4):317-320.
- Schneider E, Grehn F. Intraocular pressure measurement-comparison of dynamic contour tonometry and Goldmann applanation tonometry. *J Glaucoma*. 2006;15(1):2-6.
- Kotecha A, White ET, Shewry JM, Garway-Heath DF. The relative effects of corneal thickness and age on Goldmann applanation tonometry and dynamic contour tonometry. *Br J Ophthalmol*. 2005;89(12):1572-1575.
- Kaufmann C, Bachmann LM, Thiel MA. Comparison of dynamic contour tonometry with Goldmann applanation tonometry. *Invest Ophthalmol Vis Sci*. 2004;45(9):3118-3121.
- Kniestedt C, Lin S, Choe J, et al. Correlation between intraocular pressure, central corneal thickness, stage of glaucoma, and demographic patient data: prospective analysis of biophysical parameters in tertiary glaucoma practice populations. *J Glaucoma*. 2006;15(2):91-97.
- Kniestedt C, Lin S, Choe J, et al. Clinical comparison of contour and applanation tonometry and their relationship to pachymetry. *Arch Ophthalmol*. 2005;123(11):1532-1537.
- Ku JY, Danesh-Meyer HV, Craig JP, et al. Comparison of intraocular pressure measured by Pascal dynamic contour tonometry and Goldmann applanation tonometry. *Eye*. 2006;20(2):191-198.
- Hansen FK, Ehlers N. Elevated tonometer readings caused by a thick cornea. *Acta Ophthalmol (Copenh)*. 1971;49(5):775-778.
- Johnson M, Kass MA, Moses RA, Grodzki WJ. Increased corneal thickness simulating elevated intraocular pressure. *Arch Ophthalmol*. 1978;96(4):664-665.
- Lee GA, Khaw PT, Ficker LA, Shah P. The corneal thickness and intraocular pressure story: where are we now? *Clin Exp Ophthalmol*. 2002;30(5):334-337.
- Herndon LW. Measuring intraocular pressure-adjustments for corneal thickness and new technologies. *Curr Opin Ophthalmol*. 2006;17(2):115-119.